

# GASTRON

Headquarters / Engineering research laboratory :  
23 Gunpo Advanced Industry 1-ro(Bugok-dong), Gunpo-si, Gyeonggi-do  
Tel +82-31-490-0800 Fax +82-31-490-0801

Yeongnam business office / Plant :  
55 Gonghangap-gil 85beon-gil, Gangseogu, Busan Metropolitan City  
Tel +51-973-8518 Fax +51-973-8519

E-mail : [info@gastron.com](mailto:info@gastron.com)

[www.gastron.com](http://www.gastron.com)

# GASTRON

# GIR-3000

## Instruction Manual



# GASTRON

Read in detail for correct use.

# Gas & Flame Detection System

**GASTRON**



When abnormalities occur after purchasing the product,  
please contact the following address.

- Address : 23 Gunpo Advanced Industry 1-ro,  
Gunpo-si, Gyeonggi-do
- Tel : 031-490-0800
- Fax : 031-490-0801
- URL : [www.gastron.com](http://www.gastron.com)
- e-mail : [info@gastron.com](mailto:info@gastron.com)

We sincerely thank you for purchasing the product of Gastron Co. Ltd.

Our Gastron Co. Ltd. is a company specialized in Gas detector and Gas Monitoring System, being recognized by many consumers due to the best quality and use convenience. We always enable you consumers to find desired products nearby and are ceaselessly studying and striving for development of Gas detectors satisfying customers. From now on, solve all anguishes concerning Gas detector with the products of Gastron Co. Ltd, We Gastron Co. will take a responsibility and give you satisfaction.

In the present instruction manual, operation method for Gas detector as well as simple methods for maintenance and repair, etc. are recorded. If you read it in detail and keep it well, for reference when you have questions, then it will give you much help.

- For accurate operation of Gas detector, check up and calibrate for more than once in every 6 months.  
(\* See No. 13 of KOSHA GUIDE : P-135-2013 / 8.3 paragraph on qualification and calibration)
- For accurate operation of Gas detector, checkup and calibration with calibration gas before measurement is recommended.
- When not calibrated, it may cause malfunction of the equipment due to problems resulting from Sensor aging.
- When the present instrument should be dismantled, those with professional skills for Gas detector should conduct the operation.
- For power supply cable, wire specifications should be determined by referring to the item of "Length of installed cable".
- For the contents on checkup and calibration of Gas detector, please use our company's engineering department, e-mail, or web site.

The present product and the product manual can be changed without advance notice for performance improvement and use convenience of the product.

\* KOSHA GUIDE : P-135-2013

Calibration should be executed at the periods required by the manufacturer, and should be executed every quarter unless there are separate calibration periods.

<b>1. Overview</b> .....	6	6.3. Operation Flow .....	22
<b>2. Structure</b> .....	6	6.4. Menu Configuration Table .....	23
<b>3. Specification</b> .....	7	<b>7. System Mode</b> .....	25
3.1. Basic Specifications .....	7	7.1. PROGRAM MODE .....	25
3.2. Mechanical Specifications .....	7	7.2. CALIBRATION MODE .....	26
3.3. Electrical Specifications (Standard Type) .....	8	7.2.1. Zero Calibration .....	26
3.4. Environmental Specifications .....	8	7.2.2. Span Calibration .....	27
<b>4. Name and description of each part</b> .....	9	7.3. ALARM MODE .....	28
4.1. Components .....	9	<b>8. Troubleshooting</b> .....	30
4.2. Components of infrared sensor .....	11	8.1. Fault List .....	30
<b>5. Installation</b> .....	12	8.2. Recovery List .....	31
5.1. Separation of Housing Cover .....	12	<b>9. Interface configuration</b> .....	32
5.2. Configuration of Main PCB .....	12	9.1. MODBUS RS485 .....	32
5.3. Configuration of power supply and 4~20mA terminal .....	14	9.1.1. Interface setting .....	32
5.3.1. Wire connection diagram of driving method for 4~20mA Source .....	14	9.1.2. MODBUS RS485 Register map .....	32
5.3.2. Wire connection diagram of driving method for 4~20mA Sink .....	14	<b>10. Outline drawing and Dimensions</b> .....	33
5.3.3. Wire connection diagram of driving method for 4~20mA 3Wire Sink .....	16	10.1. Standard Type .....	33
5.4. Configuration of Relay terminal and communication terminal .....	16	10.2. Upon coupling of warning light .....	34
5.4.1. Configuration of terminal .....	16	10.3. Upon coupling of Raincover .....	35
5.4.2. Setting for Relay mode .....	17	10.4. GIR-3000 Remote Type .....	36
5.4.3. Setting for RS485 MODBUS .....	17	<b>11. Notes before installation</b> .....	37
5.5. Configuration of sensor connecting terminal .....	18	11.1. Selection of installation place(Data from occupational safety and health regulations) .....	37
5.6. Configuration of Remote Type connection .....	19	11.2. Selection of installation place (Data from safety management regulations for high-pressure gas) .....	37
5.7. Length of installed cable .....	20	11.3. Notes upon installation .....	38
<b>6. Operation Flow for sensor</b> .....	21	<b>12. Revision record</b> .....	39
6.1. Initial operation state (Power On) .....	21		
6.2. Gas measuring state (Measuring Mode) .....	21		

The GIR-3000 infrared Gas detector has been developed to prevent accidents beforehand by detecting various leaked gases generated in industry fields such as plants producing or using combustible gas, carbon monoxide, carbon dioxide, gas storage place, manufacturing processes, etc.

The GIR-3000 infrared Gas detector is installed in areas with a risk of gas leakage to display measured values with LCD, OLED installed in the detector by continuous detection of gas leakage, providing DC 4~20mA standard output, Isolation RS-485 communication signal, HART communication, and Relay contact signal of gas Alarm. Also, DC 4~20mA standard output can connect up to the maximum of 500m (upon using CVVS or CVVSB 1.5sq ↑ Shield Cable) in transmission distance of output signals of Gas detector and receiving unit while RS-485 communication signal can be transmitted up to 1,000m (upon using RS-485 exclusive line).

## 2. Structure

The GIR-3000's body is made of aluminum alloy material in a structure of complete pressure-resistant explosion-proof type (Ex d IIC T6), can be installed in the areas with a risk of leakage and explosion of all combustible gases, displaying leakage situation of gas at the installed field by embedding LCD, OLED in the Gas detector. Inside structure is comprised of liquid crystal unit displaying measured values, connector unit outputting measured values (DC 4~20mA) or Isolation RS-485 communication (Option) Signal, HART communication signal, and Alarm Signal to outside, and 2 PCB Boards. Outside structure is comprised of Sensor unit for detection of gas leakage and Cable lead-in unit (2ea). Calibration operation can be conducted outside of Gas detector body by using Magnet-bar, making maintenance and repair operation convenient.

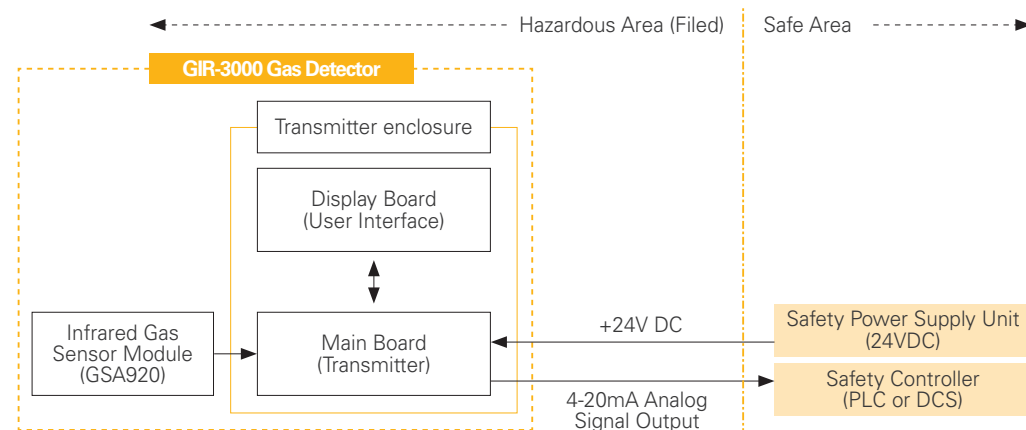

[Figure 1. GIR-3000 Overview]

### 3.1. Basic Specifications

ITEMS	SPECIFICATION	
Measuring Type	Diffusion type	
Measuring Value Display	Local Digital LCD or OLED Display	
Measuring Method	Non-Dispersive Infrared (NDIR)	
Detectible Gas	Combustible Gas	
	Carbon dioxide (CO <sub>2</sub> )	
	Carbon monoxide (CO)	
Measuring Range	Combustible:	0~9,999ppm / 0~100% LEL / 0~100% VOL
	CO <sub>2</sub> :	1.0% ~ 100% VOL
	CO:	5% ~ 100% VOL
Accuracy	≤ ±3% / Full Range	
Zero Drift	≤2% / Full Range	
Response Time	90% of full scale in less than 10 sec	
Approvals Classification	KCs: Ex d IIC T6, T4, IP65 ATEX/IECEX: II 2 G Ex d IIC Gb T4, T6 SIL2, MED, ABS, DNV	
Basic Interface	Analog 4-20mA current interface	
HART Interface	HART REV7 (Option)	
Option	HART Board	
	MODBUS RS485 Board	
	GTL-100 warning light	
	Rain Cover	
Warranty	Body (Transmitter)	2Year
	Sensor	1Year

### 3.2. Mechanical Specifications

ITEMS	SPECIFICATION	
Explosion Proof type	Pressure-resistant, explosion-proof enclosure	
Dimension	156(W) × 322(H) × 110(D) mm	
Weight including Sensor	App. 3kg	
Mounting type	Wall mount	
Mounting Holes	∅ 7 ±0.1	
Cable inlet	3/4" PF ( 1/2" or 3/4" NPT )	
Body material	Body (Transmitter)	aluminum alloy
	Sensor	Stainless Steel (STS316)

3.3. Electrical Specifications (Standard Type)

ITEMS	SPECIFICATION	
Input Voltage(Standard) ※ Customer supplied PSU must meet requirements IEC1010-1 and CE Marking requirements.	Absolute min: Nominal: Absolute max: Ripple maximum allowed:	18V 24V 31V 1V pk-pk
Wattage	Max. wattage: Max. current:	9.6W @+24 VDC 400mA @+24 VDC
Analog output Current	0-20mA(500 ohms max load) All readings ± 0.2mA Measured-value signal: 4mA(Zero) to 20mA(Full Scale)	
	Fault: 0-100% LEL: 100-109%LEL: Over 110% LEL: Maintenance:	0mA 4mA - 20mA 21.6mA 22mA 3mA
Analog output current ripple & noise max	±20uA	
Relay contact	Alarm1 , Alarm2, Fault Relay Rated 1.0 A @ 30VDC or 0.5 A @ 125 VAC	
Wiring requirement	Power	CVVS or CVVSB with shield
	Analog	CVVS or CVVSB with shield
	RS485	STP(Shielded Twisted Pair)
Signal transmission distance (Cable Connection Length)	Analog	2500m
	RS485	1000m
EMC Protection:	Complies with EN50270	

3.4. Environmental Specifications

ITEMS	SPECIFICATION	
Operation Temperature	Transmitter	-40 to 80 °C
	Sensor	-40 to 80 °C
Storage Temperature	Transmitter	-40 to 80 °C
	Sensor	-40 to 80 °C
Operation Humidity	Transmitter	5 to 99% RH (Non-condensing)
	Sensor	5 to 99% RH (Non-condensing)
Pressure Range	90 to 110KPa	
Max. air velocity	6m/s	

4.1. Components of transmitter

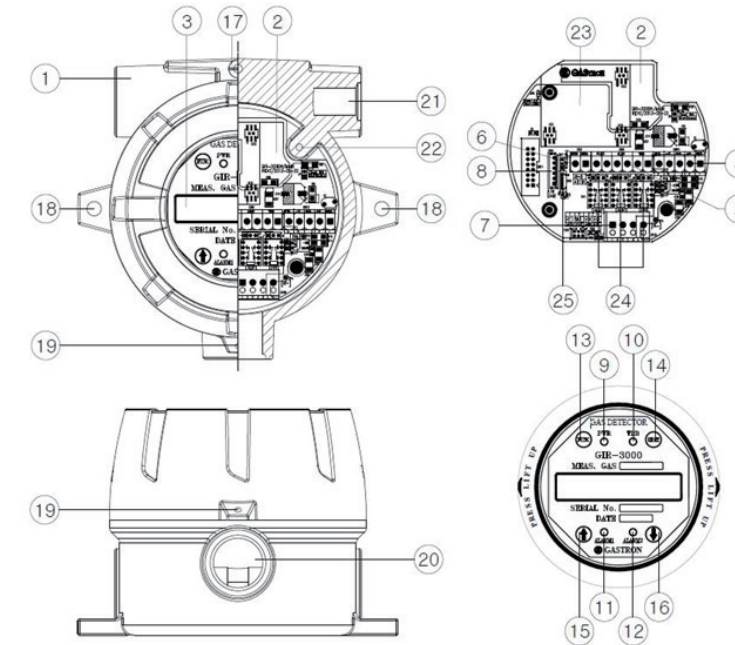

[Figure 2. Components of GIR-3000]

No	ITEMS	SPECIFICATION
1	Housing	Protect PCB Board embedded inside Sensor and Housing from change of outside environments and impact.
2	Main PCB	Amplify output signals produced by Sensor , and convert to standard output of DC 4~20mA for transmission , and output Isolation RS- 485 communication Signal and Alarm relay contact signal. Also, send Data to be displayed in Display unit.
3	Display PCB	Display Data received from MAIN PCB in LCD or OLED , and display the current Event situations by Power lamp, Alarm lamp, Trouble lamp
4	Power/Signal Terminal	CN12 is comprised of power supply of DC18-31V and DC 4~20mA standard output Connection terminal (VISO, +V, mA, -V, ETH).
5	Alarm signal Terminal	CN8 is Alarm signal connection terminal, as a terminal where Trouble, Alarm1, Alarm2 Relay contact are outputted.
6	RS-485 signal	CN3 is Isolation RS-485 communication signal connection terminal(A, B).
7	Sensor terminal	CN10 is Sensor connection terminal. (RD, WH, BK, BE)
8	Program Downloading Connector	Connector that allows downloading of product program.

### 4.1. Components of transmitter

No	ITEMS	SPECIFICATION
9	Power lamp	Lamp is lighted when .power switch is turned On
10	Trouble lamp	Lighted when abnormality occurs in circuit or sensor sensitivity , etc.
11	Alarm1 lamp	Lighted when gas is leaked to become higher than Alarm1 level
12	Alarm2 lamp	Lighted when gas is leaked to become higher than Alarm2 level
13	Function key	When contact is made for more than 2sec by using Magnet-bar upon parameter setting, it is converted to Program mode. (Program mode, Calibration mode, Test mode, etc.) Also, it is used when Data is inputted for setting.
14	Reset key	Converted when cancelled during parameter setting or touched for more than once by using Magnet bar to return to the previous state. (Converted to the previous mode by one stage at a time upon every touch.
15	↑ (Up) key	Converted or transformed by one stage at a time when touched once by using Magnet-bar upon mode conversion or figure transformation (transformed to the higher stage)
16	↓ (Down) key	Converted or transformed by one stage at a time when touched once by using Magnet-bar upon mode conversion or figure transformation(transformed to the lower stage)
17	External earth	- Outside grounding for protection from outside noise or strong electric field - For grounding cable, use conductor larger than 4mm upon coupling connection
18	Mount hole	Hole to mount Gas Detector onto outer wall and other installation place.
19	Cover fixed screw(M4)	Fix with a hexagonal lens bolt to prevent drop-off due to outside impacts after assembly of Detector Housing Body and Detector Housing Cover
20	Sensor thread	Mounting port for mounting of infrared gas sensor (Detector)
21	Cable inlet	Basically PF 3/4" is provided for power supply to Gas detector and lead-in of measurement output signals upon installation operation.
22	Internal earth	- Inside grounding of Detector for protection from outside nose or strong electric field - For grounding cable, use conductor larger than 4mm upon coupling connection.
23	RS-485 Module / HART Module	Connector to connect Isolation Type RS-485 communication Module for communication with PC or PLC and HART communication Module. For RS-485 communication, communication Address should be set, and the basic value is set for No.1. For HART communication, Polling-Address and Tag No. etc. should be set. (Optional specifications)
24	Relay Contact Type Selection	Configured so as to allow selection of A, B contact. If not in ENERGIZER MODE, it operates as contact A (Normal Open) when Jumper is connected to the part displayed as silk A, while it operates as contact B (Normal Close) when Jumper is connected to the part displayed as silk B. On the contrary, if in ENERGIZER MODE, it operates as contact B when Jumper is connected to A, while it operates as contact A when Jumper is connected to B.
25	Warning Light Connector	Connecting connector when the warning light is used(Optional)

[Table 1. Description on components of GIR-3000 transmitter]

### 4.2. Components of infrared sensor

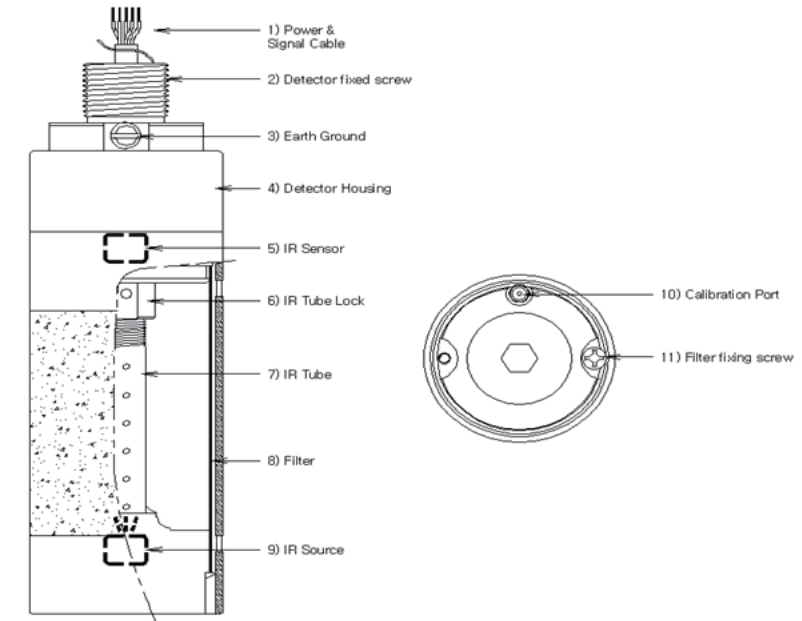

No	ITEMS	SPECIFICATION
1	Power & Signal cable	Comprised of power supply input, 4-20mA analog signal, and transmitter communication cable.
2	Detector fixed screw	Screw processing part for mounting of transmitter
3	Earth Ground	Outside grounding for protection from outside noise or strong electric field
4	Housing	Protect PCB Board embedded inside from change in outside environment or impact
5	IR Sensor	Sensor device for transformation of IR wavelength to electric signals
6	IR Tube Lock	Screw for fixing of IR tube
7	IR Tube	Optical path passing infrared wavelength generated in IR lamp
8	Filter	Filter device for protection of inside optical paths from outside contaminants
9	IR Source	Lamp for generation of infrared signals
10	Calibration port	Inlet for calibration gas upon gas calibration
11	Filter fixing screw	Screw for fixing of filter

Absolutely no one other the approved users or those of the headquarters in charge of installation and repair should be allowed to install in the field, open or operate Cover of the installed gas leakage detector. Otherwise serious damages to life and property may be inflicted. Also, make sure to shut off the power supply and conduct operation after checking whether explosive GAS remains or flammable substances are present in the surroundings.

5.1. Separation of Housing Cover

- <Warning – Do not open during current supply.>
- Cover can be separated when the cover for gas leakage detector is turned counterclockwise after slotted set
- screw for fixing of body's cover (M4 x 1ea) is turned 3~4 turns clockwise by using a hexagonal wrench (M2). When Cover is separated, LCD unit is displayed.

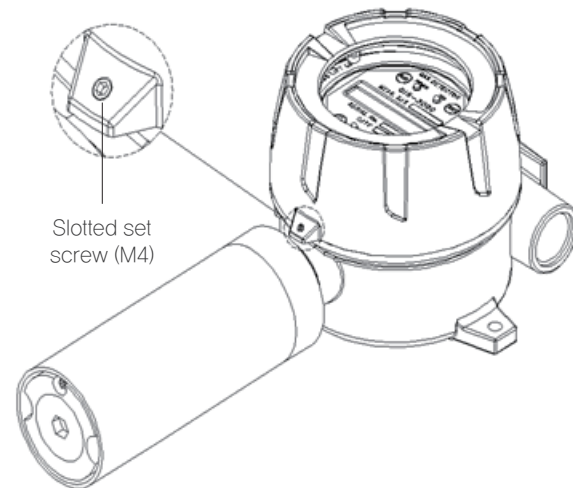

[Figure 3. Slotted set screw]

Figure when infrared  
Sensor(Detector) is mounted

- When Cover is separated, separate Display Parts in the following order.
  - ① Simultaneously push inward the fixing chains on left side and right side on the front face of LCD unit.
  - ② Separate from Gas detector body by pulling Display Parts forward in the pushed state.
  - ③ Main PCB is installed below Detector Body after separation of Display Parts .

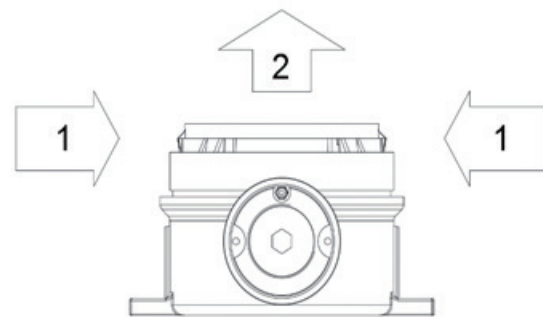

[Figure 4. Separation method for Display Part]

5.2. Configuration of Main PCB

- When Display Parts are separated, the layout diagram for Main PCB terminal as follows can be seen.

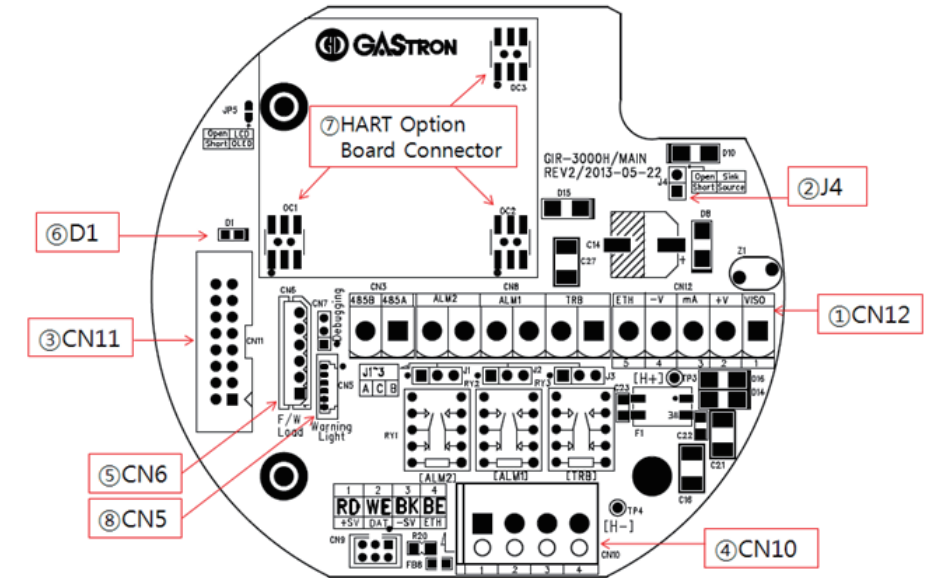

[Figure 5. Layout diagram for Main PCB terminals]

No	NAME	DESCRIPTION
1	CN12	Power & Output Signal Terminal
2	J4	4~20mA Source / Sink selection jumper (ON: Source Type, OFF: Sink Type)
3	CN11	Display LCD Connector
4	CN10	Sensor Connector
5	CN6	Program download Connector
6	D1	Status LED (Blinks by the unit of 11 sec in the case of normal operation)
7	OC1, OC2, OC3	HART Option Board Connector
8	CN5	Warning light (GTL-100) Interface Connector

[Table 3. Description on major parts of Main PCB]

- By using OC1, OC2, OC3 of the above layout diagram, HART Option or RS485 MODBUS board can be mounted, and is fixed by using 3 Ø Screw hoe on the to[ left side of Option board.

5.3. Configuration of power supply and 4~20mA terminal

- <Warning – Conduct operation after shutting off the power supply upon connection of power supply terminal.>
- When Display Parts are separated, Terminal Block in Main PCB can be seen as show in the following figure, which is separated from Main PCB when held by hand and pulled up.
- Loosen by turning counterclockwise the terminal-fixing screws at 5 places in the upper part of the separated Terminal Block CN12 (VISO, +V, mA, -V, ETH) Connector by using  $\ominus$  driver, connect DC18~31V power supply to +, -, and Signal Cable to mA, followed by locking terminal-fixing screws at 5 places clockwise to prevent terminal from breaking away, and fit it in Main PCB as before separation.

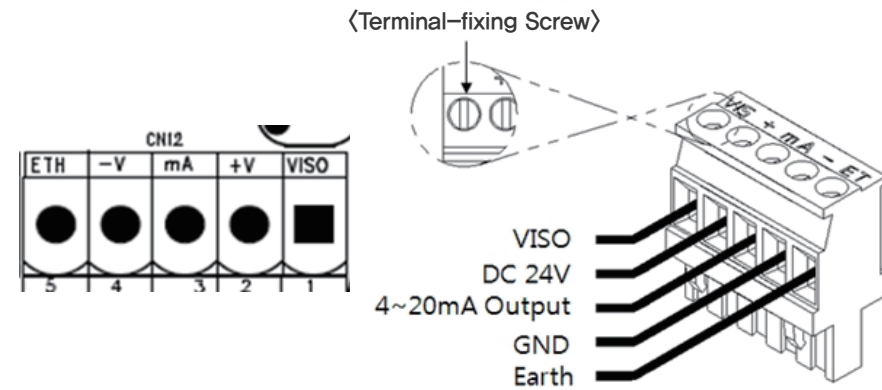

[Figure 6. Configuration of CN12 terminal]

No	PCB Silk	PIN NAME	DESCRIPTION	
			4~20mA Source Drive (J1 Jumper ON)	4~20mA Sink Drive (J1 Jumper OFF)
1	VISO	VIS	N.C	4~20mA Sink In(+)
2	+V	+	+24V / POWER (+)	
3	mA	mA	4~20mA Source Out	4~20mA Sink Out(-)
4	-V	-	GND / POWER (-)	
5	ETH	ET	EARTH	

[Table 4. Detailed description on CN12 terminal]

- Upon configuring the Terminal, use CVVS or CVVSB 2.0sq ↑ Shield Cable.
- To connect 4Pin Terminal of the existing old-style GIR-3000, fasten the terminal based on +24V as No.2 plate.

5.3.1. Wire connection diagram of driving method for 4~20mA Source

- Connect 4~20mA Signal terminal on PLC side to GIR-3000의 'mA', while GND terminal is used in common with the power supply. And then turn the J1 Jumper ON.
- HART Communicator can be used only in the model using HART Option board

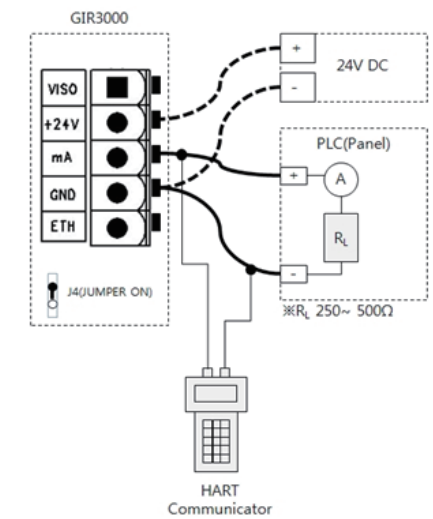

[Figure 7. Configuration of 4~20mA Source]

5.3.2. Wire connection diagram of driving method for 4~20mA Sink

- Connect 4~20mA Sink output (+) terminal on PLC side to VISO terminal, and (-) terminal to 'mA' terminal. And then turn the J1 Jumper OFF.
- HART Communicator can be used only in the model using HART Option board.

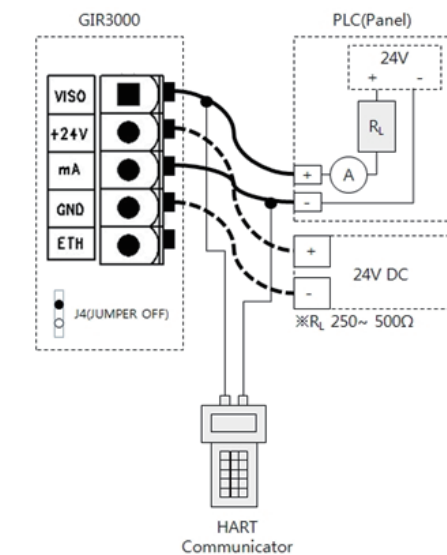

[Figure 8. Configuration of 4~20mA Sink]



5.3.3. Wire connection diagram of driving method for 4~20mA 3Wire Sink

- Connect 4~20mA Sink output (+) terminal on PLC side to VISO terminal, and (-) terminal to (24V DC) (-) terminal. Connect 'mA' terminal of GIR-3000 to 'GND' terminal. Then connect the J1 Jumper OFF.

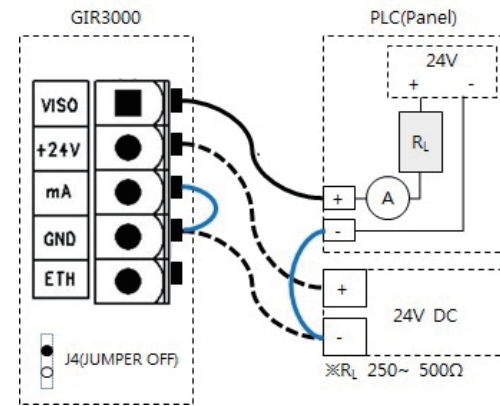

[Figure 9. Configuration of 4~20mA 3Wire Sink]

5.4. Configuration of Relay terminal and communication terminal

5.4.1. Configuration of terminal

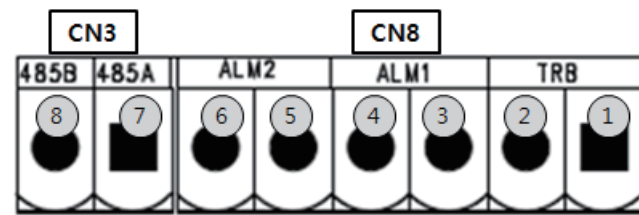

[Figure 10. Relay and RS485 Terminal]

TER. NO.	PIN NO.	TERMINAL NAME	DESCRIPTION
CN8	1	TRB OUT	Output mode is determined by TROUBLE RELAY OUTPUT terminal and J3 Jumper setting
	2	TRB COM	TROUBLE RELAY COMMON terminal
	3	AL1 OUT	Output mode is determined by ALARM1 RELAY OUTPUT terminal, J2 Jumper setting.
	4	AL1 COM	ALARM1 RELAY COMMON terminal
	5	AL2 OUT	Output mode is determined by ALARM2 RELAY OUTPUT terminal and J1 Jumper setting.
	6	AL2 COM	ALARM2 RELAY COMMON terminal
CN3	7	RS485 A	RS485 A terminal
	8	RS485 B	RS485 B terminal

[Table 5. Description on Relay and RS485 terminal]

5.4.2. Setting for Relay mode

- When power is supplied to the power supply terminal on MAIN PCB board after wiring, the following contents can be checked in LCD unit. After the initial operation power is supplied, stabilization time of about 30 minutes is required, and normal operation occurs from the time of sufficient stabilization.

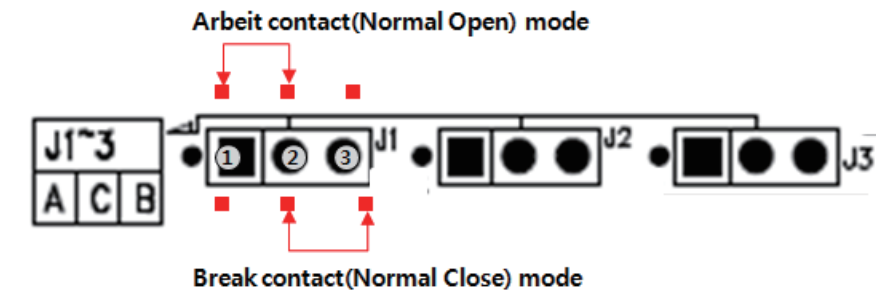

[Figure 11. Setting for Relay Mode]

- For driving of Relay of GIR-3000 product, 2 types of Normal open and Normal close are operated. To allow setting of Main PCB에 Relay driving method, Jumper is configured with operation setting as follows.

TER. NO.	PIN NO.	TERMINAL NAME	MODE 설정
CN8	1	TRB OUT	J3 A-C connection : Contact A ( Normal Open ) J3 B-C connection : Contact B ( Normal Close )
	2	TRB COM	
	3	AL1 OUT	J2 A-C connection : Contact A ( Normal Open ) J2 B-C connection : Contact B ( Normal Close )
	4	AL1 COM	
	5	AL2 OUT	J1 A-C connection : Contact A ( Normal Open ) J1 B-C connection : Contact B ( Normal Close )
	6	AL2 COM	

[Table 6. Setting for Relay Mode]

5.4.3. Setting for RS485 MODBUS

- MODBUS of GIR-3000 product is an Optional item, and is connected to the receiver unit by the following method.

TER. NO.	PIN NO.	TERMINAL NAME	RECEIVER TERMINAL NAME	NOTE
CN3	7	485A	'TRXD+' or 'A' or 'P'	
	8	485B	'TRXD-' or 'B' or 'N'	

[Table 7. Description on RS485 terminal]

5.5. Configuration of sensor-connecting terminal

- IR sensor module (to be referred to as GSA920A hereafter) is connected to the transmitter by using CN No.10 terminal.

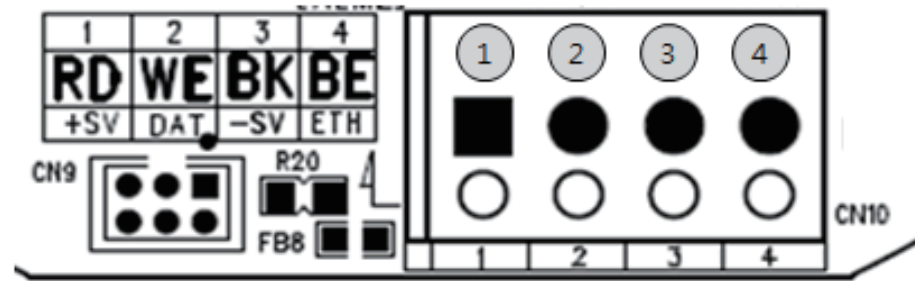

[Figure 12. Sensor-connecting terminal]

TER. NO.	PIN NO.	TERMINAL NAME	COLOR OF SENSOR CABLE	REMARKS
CN10	1	TRB OUT	TROUBLE RELAY OUT is determined	+24V sensor power supply
	2	TRB COM	TROUBLE RELAY COMMON terminal	Sensor communication with transmitter
	3	RS485 A	RS485 A terminal	Sensor power supply GROUND
	4	RS485 B	RS485 B terminal	EARTH

[Table 8. Description on sensor-connecting terminal]

- Configuration of the cable with wire connection to GSA920A is as follows.
  - GSA920A module allows configuration of extension cable, and is connected by using CN10 terminal of transmitter.
  - GSA920A Option1 is an exclusive output of 4-20mA, while the relevant option is used upon sole installation of GSA920A
  - GSA920A Option2 is an exclusive Zero port, while the relevant option is used upon sole installation of GSA920A.

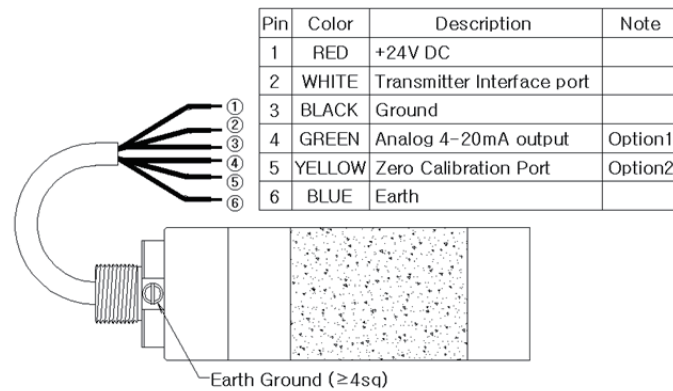

[Figure 13. Configuration of connection for GSA920A]

5.6. Configuration of Remote Type connection

- To remotely configure GSA920A, the sensor is installed by using Junction Box(GDH-1010) of the following form, and connection is made to GIR-3000 transmitter by using component terminal inside Junction Box.

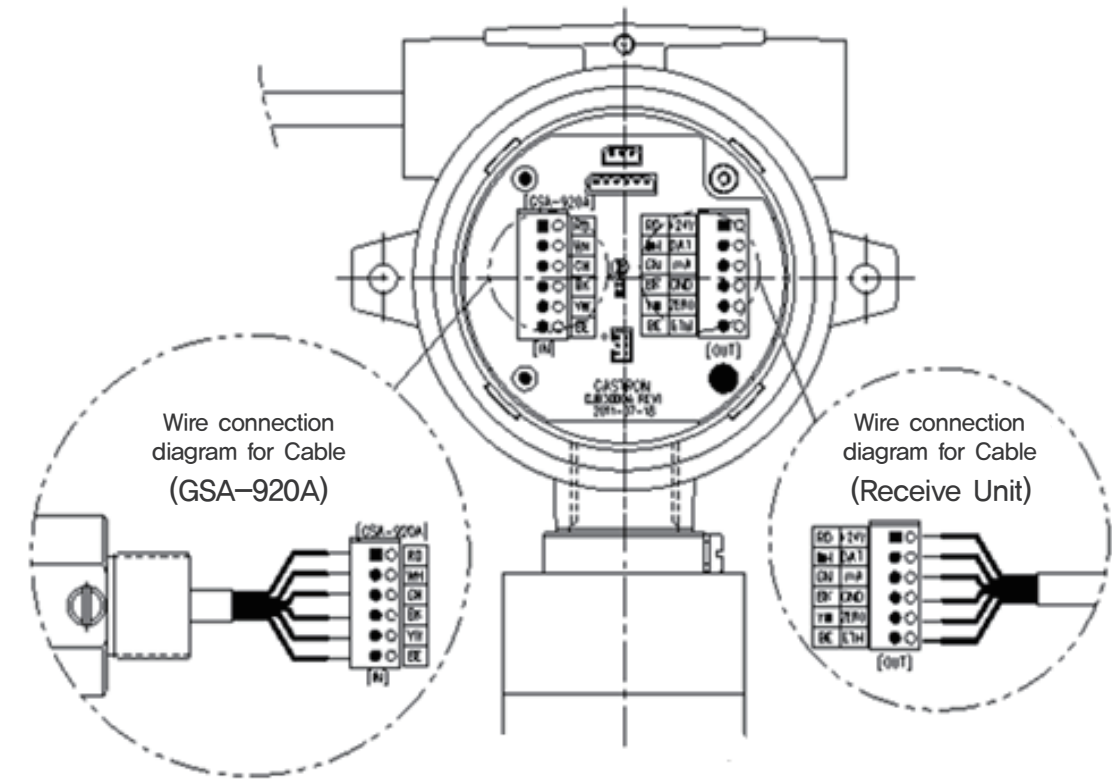

[Figure 14. Configuration for GSA-920A Remote Type]

5.7. Length of installed cable

- The maximum length between GIR-3000 and power supply is determined by the wire specifications.
- Maximum installation length=  $V_{MAXDROP} \div I_{MAX} \div WIRER/m \div 2$
- $V_{MAXDROP}$ : Maximum Power Loop Voltage Drop (=Power Supply voltage – min operating voltage)
- $I_{MAX}$ : Maximum current value of GIR-3000
- $WIRER/m$ : The resistance of the wire (ohms/meter value available in wire manufacturer's specification data sheet),
- An example for installation length using 24V power supply and 16AWG is as follows.
- GIR-3000 minimum operating voltage = 18 Vdc
- $V_{MAXDROP} = 24 - 18 = 6V$
- $I_{MAX} = 0.4A(400mA)$
- $6 \div 0.4 \div 0.01318 \div 2 = 569.044m \approx 569m$

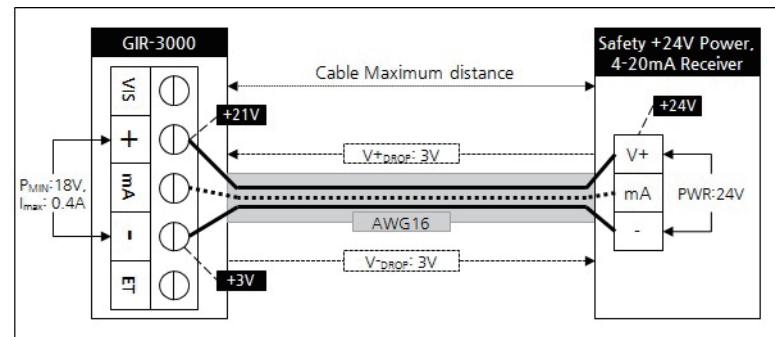

[Figure 15. Calculation of length for GIR-3000 installation cable]

PIN NO.	mm <sup>2</sup>	COPPER RESISTANCE(ohms/m)	METERS
12	3.31	0.00521	1439
14	2.08	0.00828	905
16	1.31	0.01318	569
18	0.82	0.02095	357
20	0.518	0.0333	225

[Table 9. Installation length for GIR-3000 power supply cable]

6.1. Initial operation state(Power On)

- When power is supplied to the power supply terminal on MAIN PCB board after wiring, the following contents can be confirmed in the LCD unit, a stabilization time of about 30 minutes is required after initial supply of operation power, and normal operation occurs from the time of sufficient stabilization.

GIR-3000 V X.XX / V X.XX	- When the power supply is turned ON, model name of LCD(OLED) is displayed in the 1st row, while firmware version of the transmitter and firmware version of the sensor unit are displayed in the 2nd row. - When GSA920A firmware Version is being Read, "Reading" is marked, When Read fails, "Fail" is marked.
** SELFTEST ** [>>>>>> 0180]	- SELFTEST is executed for 3 minutes, while ')' character in the 2nd row informs progress state with the progress count being displayed.

6.2. Gas Measuring Mode

- When there is abnormality in SELF TEST after power is turned ON, automatic entry occurs in the following state of gas measurement.

[ CH4 ] [ WAIT ]%LEL	- When the sensor unit is in waiting state even if progress occurs in a Normal state after SELF TEST, measured GAS NAME is displayed in the 1st row, while "WAIT" is displayed by the unit of 1 second in the 2nd row.
[ CH4 ] [ 0 ]%LEL	- When it is in gas measurement state while being in Normal state, it operates as follows. - Measured GAS NAME is displayed in the 1st row, while current measured value and unit are displayed in the 2nd row. ※ During communication with the sensor unit, '#' character is displayed in the left-side part of GAS NAME. ※ During HART communication or 485 communication, '*' character is displayed in the left-side part of the 1st row.
# [ CH4 ] [ 0 ]%LEL	※ When ENG. Mode is turned ON, the current temperature is displayed in the left-side part of the 2nd row.
*# [ CH4 ] [ 0 ]%LEL	- When more than 10% than the High Scale with setting of gas measurement value is inputted, the text of "OVER" is displayed by the unit of 1 second. At this time, 4~20mA is operated as 22mA.
*# [ CH4 ] [ UNDER ]%LEL	- When the gas measurement value is inputted as less than -10%. The text of "UNDER" is displayed by the unit of 1 second, and 4~20mA is operated as 0mA. (2mA upon use of HART) - The relevant function operates when UNDER function is turned ON.
FAULT 04 > SEN-COMT/O	- When there is abnormality in the device, Fault No. and message are outputted. - At this time, 4~20mA is operated as 0mA. (2mA upon use of HART) - The left side is in Fault 4 state occurring when the sensor is not mounted.

6.3. Operation Flow

- After Power is turned On, undergo the self diagnosis process and enter in the measuring mode. At this time entering inside system mode is possible through the front face key operation.
- Timeout between Level1 and Level2 is 10 seconds, while it is configured as 1 hour in calibration of and Test Mode.
- When "RESET" key is touched in program Mode screen, it is returned to measuring state, while it is returned to the upper stage when "RESET" key is touched in each program setting screen.

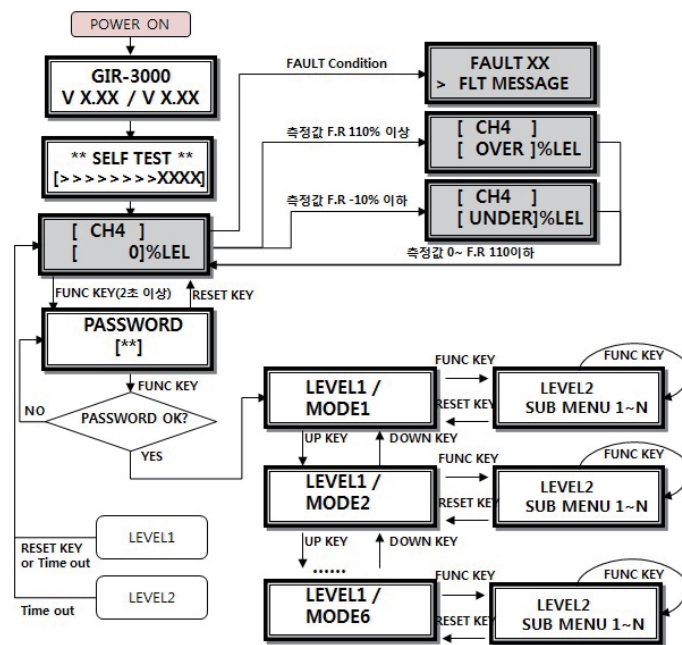

[Figure 16. Configuration of GIR-3000 mode]

ITEM	NAME	DESCRIPTION
FUNC	Function key	Entry function for sensor Mode setting (Input with Magnet-bar for more than 2 seconds in the measuring mode) . Entry function for the next stage of Level2 and saving function for setting values
RESET	Reset key	Move to the stage before the entered LEVEL
↑	Up key	Change the setting value Plus for the next stage mode configured in LEVEL1 and Level2
↓	Down key	Change the setting value Minus for the next stage mode configured in LEVEL1 and Level2

[Table 10. Description on operation key]

6.4. Menu Configuration Table

LEVEL1	LEVEL2		DEFAULT
	NAME	PARAMETER	
PROGRAMMABLE MODE	GROUP OF GAS SEL (GROUP OF GAS SELECT)	HC/PROPANE/CO/CO2/SO2/VCM/FREON	HC
	UNIT & TAG SEL. (UNIT & TAG SELECT)	%/%LEL/PPM/PPB	%LEL
	DECIMAL POINT	0.100/1.00/10.0/100	100
	HIGH SCALE ADJ. (HIGH SCALEADJUST)	1~9999	100
	PASSWORD SET	00~99	100
CALIBRATION MODE	CALIBRATION [ZERO& SPAN]	ZERO CALIBRATION [NO, YES]	[NO]
		ZERO GAS [0]	
		ZERO PROCESSING [SUCCESS / FAIL]	
		CALIBRATION DATA [ 0]	
		SPAN CALIBRATION [NO, YES]	[NO]
		SPAN GAS VALUE [ 0]	Full Scale의 50%
		[CH4] SPAN GAS 000 [ 0]	
		SPAN PROCESSING [SUCCESS / FAIL ]	
		CALIBRATION DATA [ 0]	
ALARM PROGRAM MODE	ALARM OPERATING	[AUTO/MANUAL]	AUTO
	ALARM RELAY TYPE	DE-ENERGIZED/ENERGIZED	DE-ENERGIZED
	FAULT RELAY TYPE	DE-ENERGIZED/ENERGIZED	DE-ENERGIZED
	ALARM1 TYPE SEL. (ALARM1 TYPESELECT)	[INCREASE/ DECREASE]	INCREASE
	ALARM1 LEVEL ADJ (ALARM1 LEVEL ADJUST)	[1~Full Scale]	20
	ALARM1 DEAD BAND	[0.0~ Full Scale의10%]	0.0
ALARM1 RELAY CTL (ALARM RELAY CONTROL)	[ON / OFF]	ON	

6.4. Menu Configuration Table

LEVEL1	LEVEL2		DEFAULT
	NAME	PARAMETER	
ALARM PROGRAM MODE	ALARM1 TIME SET	[0~60] SEC	01
	ALARM2 TYPE SEL. (ALARM2 TYPE SELECT)	INCREASE/ DECREASE	INCREASE
	ALARM2 LEVEL ADJ (ALARM2 LEVEL ADJUST)	[1~Full Scale]	40
	ALARM2 DEAD BAND	[0.0 ~ Full Scale <sup>2</sup> 10%]	0.0
	ALARM2 RELAY CTL (ALARM RELAY CONTROL)	[ON / OFF]	ON
	ALARM2 TIME SET	[0~60] SEC	01
TEST MODE	Factory Mode		
IR SENSOR DATA MODE	Factory Mode		
VERSION MODE	Factory Mode		
MAINTENANCE MODE	Factory Mode		
485MODBUS MODE	Factory Mode		
DEVICE MODE	Factory Mode		
SYSTEM MODE	Factory Mode		

[Table 11 . Menu Configuration Table]

7.1. PROGRAM MODE

<b>PROGRAMMABLE MODE</b>	<ul style="list-style-type: none"> <li>- Enter in the Level1 mode after Password checking.</li> <li>- "Select PROGRAMMABLE MODE by touching "↑" key or "↓" key.</li> <li>- When Function key is touched at this time , PROGRAMMABLE MODE Level2 serve menu is entered in.</li> </ul>
<b>GROUP OF GAS SEL [ HC ]</b>	- Mode for setting Gas group with Gas name being changed whenever "↑"key or "↓" key is touched. (HC/PROPANE/CO/CO2/SO2/VCM/FREON)
<b>TYPE OF HC [ CH4 ]</b>	- Mode for setting Gas name with Gas name being changed whenever "↑"key or "↓" key is touched.
<b>TYPE OF HC [ CH4 ]</b>	- Mode for setting Gas measurement unit with the Gas measurement unit being changed whenever "↑"key or "↓" key is touched. (% / %LEL / PPM / PPB ).
<b>DECIMAL POINT [ 100 ]%LEL</b>	- Mode for setting position of decimal point with the position of decimal point being changed whenever "↑"key or "↓" key is touched. (0.100/1.00/10.0/100)
<b>HIGH SCALE ADJ. [ 100 ]%LEL</b>	- Mode for setting High scale value to be displayed at the time of Full Range with the scale value being increased or decreased whenever "↑"key or "↓" key is touched. ( 1 ~ 9999 )
<b>PASSWORD SET [00]</b>	- Mode for setting Password , which is checked upon entering in the Program Mode. ( 0~99 )

### 7.2. CALIBRATION MODE

- Due to the characteristics of Gas detector, a stabilization time of at least about 30 minutes is required after supply of power, and the management criteria may be varied with field conditions..

#### 7.2.1. Zero Calibration

<b>CALIBRATION MODE</b>	<ul style="list-style-type: none"> <li>Enter in Level1 mode after Password checking.</li> <li>Select CALIBRATION MODE by touching "↑" key or "↓" key.</li> <li>Calibration Mode Level2 sub menu is entered in when Function key is touched at this time.</li> </ul>
<b>CALIBRATION [ZERO]</b>	<ul style="list-style-type: none"> <li>Calibration mode is entered in if FUC key is touched when it is [ZERO].</li> <li>ZERO and SPAN can be selected by touching "↑" key or "↓" key.</li> </ul>
<b>ZERO CALIBRATION [YES]</b>	<ul style="list-style-type: none"> <li>Zero Calibration is executed if FUNC key is touched when it is [YES] by touching "↑" key or "↓" key.</li> </ul>
<b>ZERO GAS [ 0]%LEL</b>	<ul style="list-style-type: none"> <li>Zero calibration is automatically executed if FUNC key is touched when the measured value is stabilized after clean air or 100% nitrogen as the gas is injected in the sensor unit at the flow rate of 1000mL/min for about 1 minute by using a calibration apparatus.</li> </ul>
<b>ZERO PROCESSING &gt;&gt;&gt;&gt;</b>	<ul style="list-style-type: none"> <li>Processing state of Zero calibration is displayed.</li> </ul>
<b>ZERO PROCESSING SUCCESS</b>	<ul style="list-style-type: none"> <li>When Zero calibration is successful, "ZERO CALIBRATION SUCCESS is displayed in LCD Display for 2 seconds, and then converted to CALIBRATION DATA Mode.</li> </ul>
<b>ZERO PROCESSING FAIL</b>	<ul style="list-style-type: none"> <li>When Zero Calibration is not successful, "ZERO CALIBRATION FAIL" is displayed for 2 seconds, and then converted to CALIBRATION DATA Mode.</li> </ul>
<b>CALIBRATION DATA [WAIT ]%LEL</b>	<ul style="list-style-type: none"> <li>Mode for displaying measured values after calibration, as a function for checking whether calibration was normal after execution of calibration.</li> </ul>
<b>CALIBRATION DATA [ 0]%LEL</b>	<ul style="list-style-type: none"> <li>"WAIT" is displayed for 2 seconds after entering in Sub menu, displaying the current measurement state.</li> <li>When RESET key is touched, it is returned to "CALIBRATION MODE"</li> <li>When FUNC key is touched, Span Calibration menu is entered in.</li> </ul>

#### 7.2.2. Span Calibration

<b>SPAN CALIBRATION [YES]</b>	<ul style="list-style-type: none"> <li>Span Calibration Mode is entered in if FUNC key is touched when it is [YES] by touching "↑" key or "↓" key.</li> </ul>
<b>[CH4] SPAN GAS 090 [ 50]%LEL</b>	<ul style="list-style-type: none"> <li>Span calibration is automatically executed if FUNC key is touched when the measured value is stabilized after the standard gas is injected in the sensor unit at the flow rate of 1000mL/min for about 90 seconds by using a calibration apparatus.</li> </ul>
<b>SPAN GAS VALUE [ 50]</b>	<ul style="list-style-type: none"> <li>Mode for setting standard gas value where FUNC key is touched after the value is set by touching "↑" key or "↓" key. (1~Full Scale)</li> </ul>
<b>SPAN PROCESSING &gt;&gt;&gt;&gt;</b>	<ul style="list-style-type: none"> <li>Processing state of Span calibration is displayed.</li> </ul>
<b>SPAN PROCESSING SUCCESS</b>	<ul style="list-style-type: none"> <li>When Span calibration is successful, "SPAN PROCESSING SUCCESS" is displayed in LCD Display for 2 seconds, and then converted to CALIBRATION DATA Mode.</li> </ul>
<b>SPAN PROCESSING FAIL</b>	<ul style="list-style-type: none"> <li>When Span Calibration is not successful, "SPAN PROCESSING FAIL" is displayed in LCD Display for 2 seconds, and then converted to CALIBRATION DATA Mode.</li> </ul>
<b>CALIBRATION DATA [WAIT ]%LEL</b>	<ul style="list-style-type: none"> <li>Mode for displaying measured values after calibration, as a function for checking whether calibration was normal after execution of calibration.</li> </ul>
<b>CALIBRATION DATA [50]%LEL</b>	<ul style="list-style-type: none"> <li>"WAIT" is displayed for 2 seconds after entering in Sub menu, displaying the current measurement state.</li> <li>When "RESET" key or "FUNC" key is touched, it is returned to "CALIBRATION MODE".</li> </ul>

### 7.3. ALARM MODE

<b>ALARM PROGRAM MODE</b>	<ul style="list-style-type: none"> <li>– Enter in Level1 mode after password checking.</li> <li>– Select ALARM MODE by touching "↑"key or "↓"key.</li> <li>– ALARM MODE Level2 is entered in when Function key is touched at this time.</li> </ul>
<b>ALARM OPERATING [ AUTO ]</b>	<ul style="list-style-type: none"> <li>– Mode for setting Resetting method after Alarm operation with change to "AUTO" and "MANUAL" whenever "↑"key or "↓"key is touched.</li> </ul>
<b>ALARM OPERATING [ MANUAL ]</b>	<ul style="list-style-type: none"> <li>– "AUTO" Mode is the function for automatic resetting of Alarm, while "MANUAL" Mode is the function for resetting of Alarm by pushing the Reset key.</li> </ul>
<b>ALARM RELAY TYPE DE-ENERGIZED</b>	<ul style="list-style-type: none"> <li>– Mode for setting Relay driving method after Alarm operation with change to "DE-ENERGIZED" and "ENERGIZED" whenever "↑"key or "↓"key is touched.</li> <li>– "DE-ENERGIZED" is the function for deactivation of energizer mode, while "ENERGIZED" activates the energizer mode.</li> </ul>
<b>FAULT RELAY TYPE DE-ENERGIZED</b>	<ul style="list-style-type: none"> <li>– Mode for setting Relay driving method after FAULT operation with change "DE-ENERGIZED" and "ENERGIZED" whenever "↑"key or "↓"key is touched.</li> <li>– "DE-ENERGIZED" is the function for deactivation of energizer mode, while "ENERGIZED" activates the energizer mode.</li> </ul>
<b>ALARM1 TYPE SEL. [ INCREASE ]</b>	<ul style="list-style-type: none"> <li>– Mode for setting operation direction for Alarm1 with "INCREASE" or "DECREASE" displayed whenever "↑"key or "↓"key is touched.</li> </ul>
<b>ALARM1 TYPE SEL. [ DECREASE ]</b>	<ul style="list-style-type: none"> <li>– "INCREASE" Mode is the mode operating when it is larger than or same as the setting value for Alarm1 while "DECREASE" Mode is the mode operating when it is smaller than or the same as the setting value for Alarm1.</li> </ul>
<b>ALARM1 LEVEL ADJ [ 20 ]</b>	<ul style="list-style-type: none"> <li>– Mode for setting the Alarm1 level value with the Alarm 1 value increased or decreased whenever "↑"key or "↓"key is touched.</li> <li>– If "FUNC" key is touched when the desired Alarm1 value is displayed, and the next Alarm Program item is entered in.</li> </ul>
<b>ALARM1 DEAD BAND</b>	<ul style="list-style-type: none"> <li>– Mode for setting the range for operation of Alarm1 with increase or decrease whenever "↑"key or "↓"key is touched.</li> <li>– Function where Alarm1 operates at the Alarm1 value plus Deadband value when Alarm1 is in "INCREASE" Mode and Alarm 1 is cleared at the Alarm1 value minus Dead band value.</li> <li>– If "FUNC" key is touched when the desired value is displayed, Deadband value is set and the next Alarm Program item is entered in.</li> </ul>
<b>ALARM1 RELAY CTL [ ON ]</b>	<ul style="list-style-type: none"> <li>– Mode for setting whether to control Relay contact when Alarm1 operates with "ON" or "OFF" displayed whenever "↑"key or "↓"key is touched.</li> <li>– If it is turned ON, Relay operates upon operation of Alarm 1. When it is turned OFF, Relay does not operate when Alarm 1 operates.</li> </ul>
<b>ALARM1 TIME SET [ 01 ]</b>	<ul style="list-style-type: none"> <li>– Mode for setting delay time for Alarm 1 with the value increased or decreased whenever "↑"key or "↓"key is touched.</li> <li>– Displayed figure shows seconds, being displayed from 0 to 60. If "FUNC" key is touched when the desired value is displayed, alarm delay time is set and then the next Alarm Program item is entered in.</li> </ul>

### 7.3. ALARM MODE

<b>ALARM2 TYPE SEL. [ INCREASE ]</b>	<ul style="list-style-type: none"> <li>– Mode for setting the direction for operation of Alarm2 with "INCREASE" or "DECREASE" displayed whenever "↑"key or "↓"key is touched.</li> </ul>
<b>ALARM2 TYPE SEL. [ DECREASE ]</b>	<ul style="list-style-type: none"> <li>– "INCREASE" Mode is the mode operating when it is larger than or the same as the setting value for Alarm2, while "DECREASE" Mode is the mode operating when it is smaller than or the same as the setting value for Alarm2.</li> </ul>
<b>ALARM2 LEVEL ADJ [ 40 ]</b>	<ul style="list-style-type: none"> <li>– Mode for setting the value of Alarm2 level with Alarm2 value increased or decreased whenever "↑"key or "↓"key is touched.</li> <li>– If "FUNC" key is touched when the desired Alarm2 value is displayed, Alarm2 value is set, and then Alarm Program item is entered in.</li> </ul>
<b>ALARM2 DEAD BAND</b>	<ul style="list-style-type: none"> <li>– Mode for setting of operation range for Alarm2, with the value increased or decreased whenever "↑"key or "↓"key is touched.</li> <li>– Function where Alarm2 operates at the Alarm1 value plus Deadband value when Alarm2 is in "INCREASE" Mode and Alarm 2 is cleared at the Alarm1 value minus Dead band value.</li> <li>– If "FUNC" key is touched when the desired value is displayed, Deadband value is set and the next Alarm Program item is entered in.</li> </ul>
<b>ALARM2 RELAY CTL [ ON ]</b>	<ul style="list-style-type: none"> <li>– Mode for setting whether to control Relay contact when Alarm2 operates with "ON" or "OFF" displayed whenever "↑"key or "↓"key is touched.</li> <li>– If it is turned ON, Relay operates upon operation of Alarm 2. When it is turned OFF, Relay does not operate when Alarm 2 operates.</li> </ul>
<b>ALARM2 TIME SET [ 01 ]</b>	<ul style="list-style-type: none"> <li>– Mode for setting delay time for Alarm 2 with the value increased or decreased whenever "↑"key or "↓"key is touched.</li> <li>– Displayed figure shows seconds, being displayed from 0 to 60. If "FUNC" key is touched when the desired value is displayed, alarm delay time is set and then it returns to ALARM PROGRAM MODE.</li> </ul>

### 8.1. Fault List

FAULT MESSAGE	DESCRIPTION & CONDITION	CAUSE FOR OCCURRENCE
FAULT0 ") TSM-MEM C/S"	When Memory(FLASH, RAM) Check Sum error occurs inside the transmitter	Transmitter inside MPU defective
FAULT1 ") TSM-EEPROM"	When EEPROM Check Sum error or EEPROM operation error occurs inside the transmitter	Transmitter inside EPROM defective
FAULT2 ") SEN-MEM C/S"	When Memory(FLASH, RAM) Check Sum error occurs inside the sensor unit	Sensor Unit inside MPU defective
FAULT3 ") SEN-EEPROM"	When operation error occurs inside the sensor unit	Sensor Unit inside EEPROM defective
FAULT4 ") SEN-COM T/O"	When communication between Transmitter and Sensor Unit fails	Communication between Transmitter and Sensor Unit defective
FAULT5 ")SEN-CHANGE(DET)"	When IR Detector Channel inside the sensor unit lies below the effective voltage range (0.1V)	1) Waveguide inside sensor Unit contaminated 2) IR sensor inside sensor unit broken down
FAULT6 ")SEN-CHANGE(REF)"	When IR Reference Channel inside the sensor unit lies below the effective voltage range (0.1V)	1) Waveguide inside sensor Unit contaminated 2) IR sensor inside sensor unit broken dow
FAULT7 ")SEN-CHANGE(OPT)"	When IR Detector Channel and Reference Channel inside the sensor unit lie simultaneously below the effective voltage range (0.1V)	1) Waveguide inside sensor Unit contaminated 2) IR sensor inside sensor unit broken down 3) IR lamp inside sensor unit broken down
FAULT8 ")CLIBRATION ERR"	Calibration Error	Erroneous Calibration Parameter
FAULT9 ") SEN-D,R CH LOW"	When IR Detector Channel and Reference Channel inside the sensor unit lie simultaneously below the effective voltage range (0.1V)	1) Waveguide inside sensor Unit contaminated 2) IR sensor inside sensor unit broken down 3) IR lamp broken down
FAULT10 ")SEN-TEMPERATURE"	When IR inside temperature sensor deviates from the effective measurement range (+80 ~ - 40°C)	Surrounding temperature inspection, temperature sensor inside sensor unit defective
FAULT11 ")SEN-VERSION"	When Version of the sensor unit sensor received from transmitter is not an effective value (0~99)	Sensor Unit program error
FAULT12 ")VIN LOW VOLTAGE"	When the input voltage value is less than the minimum value (17V)	Inspection of input power supply for transmitter
FAULT13 ") HW VERSIONERR"	HW VERSION ERROR	Transmitter inside MPU defective
FAULT14 ")SENSOR HUNTING"	When the gas measurement value is repeatedly hunting	Sensor output state defective or checking for input power supply noise

[Table 9. Fault List]

### 8.2. Recovery List

No	CAUSE FOR OCCURRENCE	COPING MEASURE
1	MPU inside transmitter defective	Replace Transmitter Main Board
2	EPROM inside transmitter defective	1) Revise and recalibrate Parameter after execution of plant initialization 2) Replace Main Board when the same phenomenon occurs
3	MPU inside sensor unit defective	Replace Sensor Unit
4	EEPROM inside sensor unit defective	1) Revise and recalibrate Parameter after execution of plant initialization 2) Replace Sensor Unit when the same phenomenon occurs
5	Communication between Transmitter and Sensor Unit defective	1) Check wire connection between Transmitter and Sensor Unit 2) Check supplied voltage for Sensor Unit when there is no abnormality in wire connection 3) Replace Sensor Unit when there is no abnormality in supplied voltage 4) Replace Transmitter Main Board when the same error occurs
6	Waveguide for sensor Unit contaminated	1) Conduct cleaning operation or replacement of waveguide or optical window after removing the sensor filter 2) Execute recalibration after waveguide action
7	IR sensor broken down	Replace sensor Unit
8	Erroneous Calibration Parameter	1) Execute recalibration 2) Replace sensor Unit when the same symptom is discovered after recalibration
9	IR lamp broken down	Execute recalibration after replacement of IR lamp
10	Temperature sensor inside sensor unit defective	Replace sensor Unit
11	Sensor Unit program error	Replace sensor Unit
12	Inspection of input power supply for transmitter	Inspect the range of input power supply for transmitter

[Table 12. Recovery List]



9.1. MODBUS RS485

9.1.1. Interface setting

- Data Format: RTU
- Baud rate: 9600 bps
- Data bits: 8bits
- Stop bit: 1bits
- Parity: Even
- See www.modbus.org for other details

9.1.2. MODBUS RS485 Register map

CLASSIFICATION	ADDRESS	BITS	DESCRIPTION
Measured gas concentration	30001	BIT15~0	Gas measurement value (Integer type / Decimal Point not considered)
Setting value for High Scale	30002	BIT15~0	Setting value for High Scale (Integer type / Decimal Point not considered)
1st Alarm setting value	30003	BIT15~0	1st Alarm setting value (Integer type / Decimal Point not considered)
2nd Alarm setting value	30004	BIT15~0	2nd Alarm setting value (Integer type / Decimal Point not considered)
Gas detector state value	10000	BIT0	Alarm 1 Active state
		BIT1	Alarm 2 Active state
		BIT2	Fault Active state
		BIT3	Maintenance Mode state
		BIT4	Test Mode state
		BIT5	Calibration Mode state
		BIT6	Reserved
		BIT7	Toggle Bit(Bit inversion at an interval of 2 Sec)
Outside Test	3	BIT0~7	Setting for Gas detector Test Mode
Outside Reset	2	BIT0~7	Setting for Gas detector Test Mode

[Table 13. RS485 MODBUS Address 구성]

10.1. Standard Type

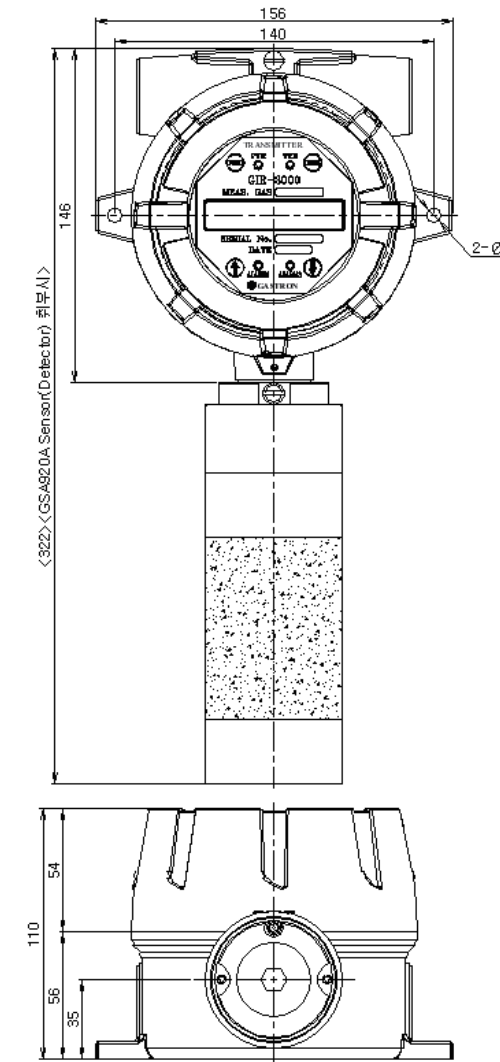

[Figure 17. outline drawing for GIR-3000 Standard Type]

#### 10.2. Upon coupling of warning light

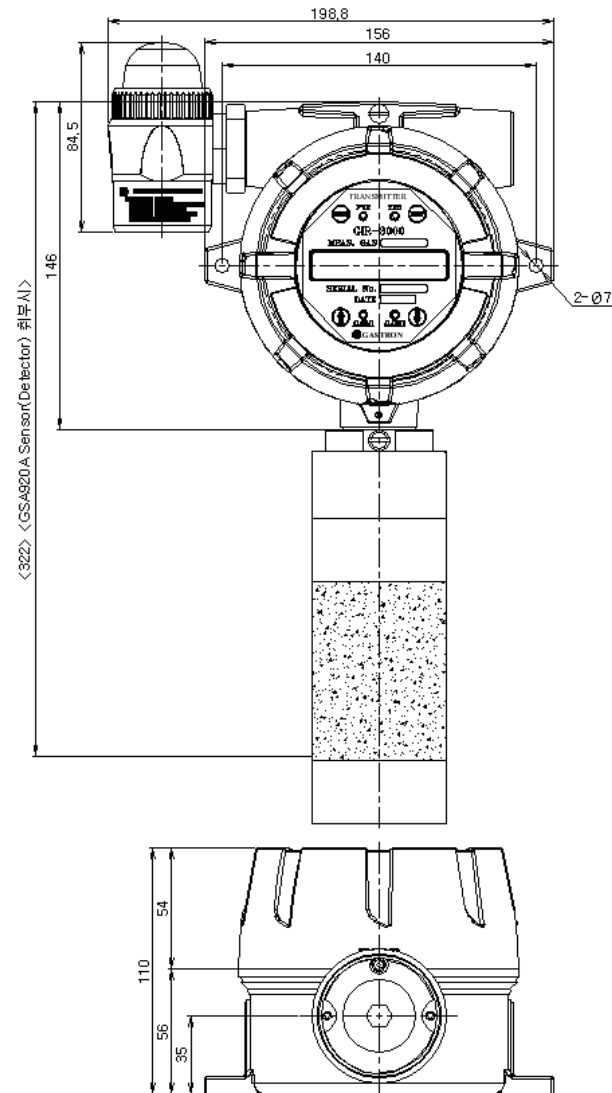

[Figure 18. Outline drawing for coupling of GIR-3000 warning light]

#### 10.3. Upon coupling of Raincover

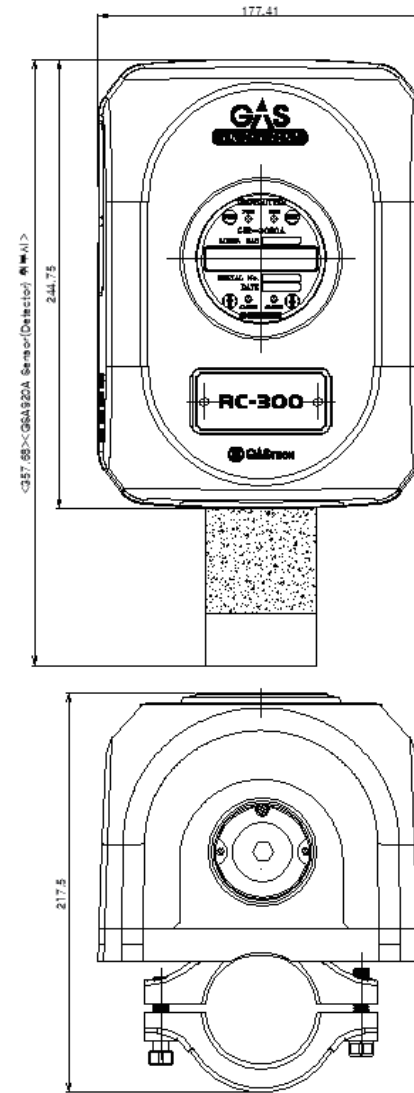

[Figure 18. Outline drawing for coupling of GIR-3000 warning light]

10.4. GIR-3000 Remote Type

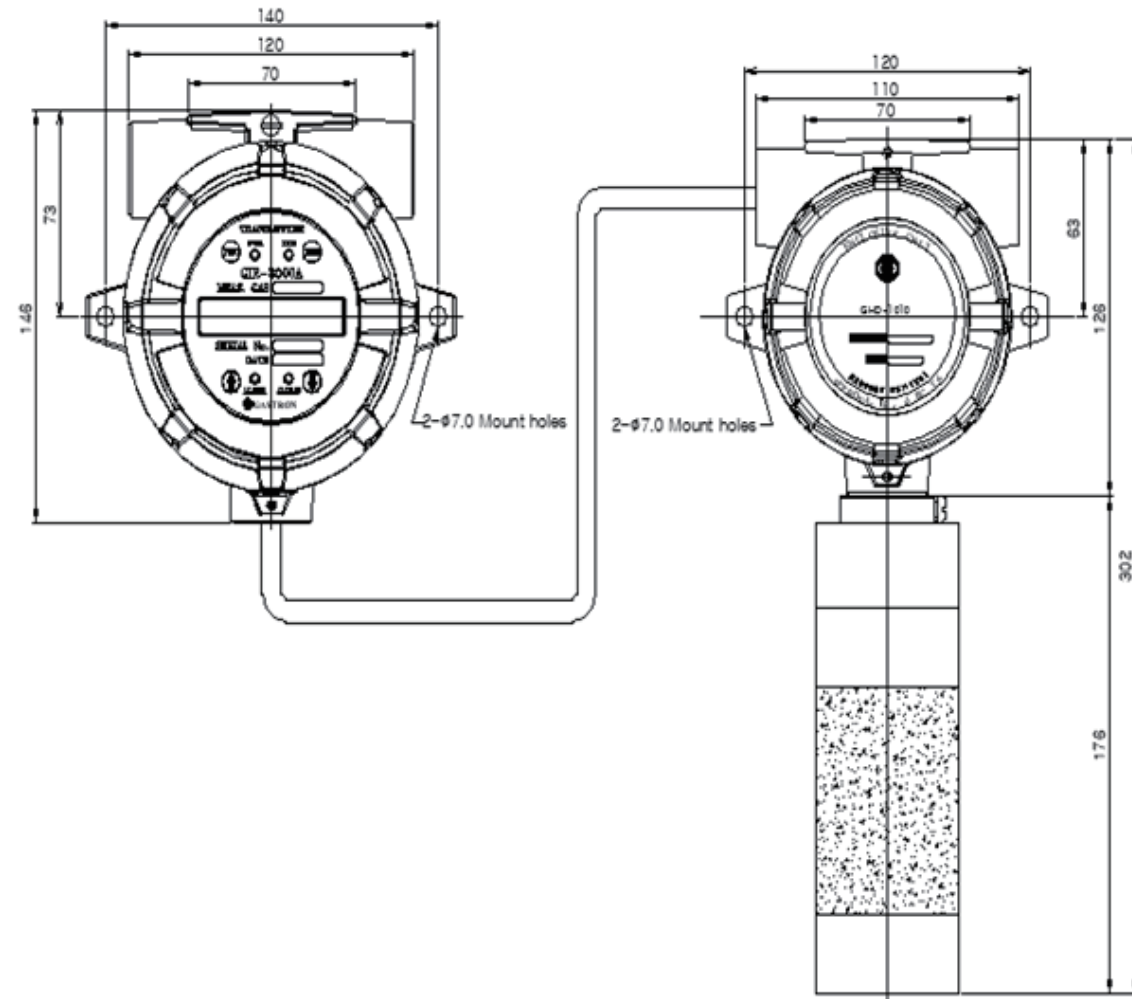

[Figure 20. GIR-3000 remote Type]

11.1. Selection of installation place (Data from occupational safety and health regulations)

The place to install the gas leakage detection alarm is as follows.

- Surroundings of chemical equipment or accessory equipment with a risk of gas leakage such as compressor, valve, reactor, piping connection part, etc. dealing with combustible and toxic substances that are installed inside and outside buildings
- Places for easy dwelling of gas around manufacturing equipment with ignition sources such as heating furnace, etc.
- Surroundings of connection part of charging equipment for combustible and toxic substances
- Substation, power distribution panel room, control room, etc. positioned within explosion-proof area
- Other places for especially easy dwelling of gas

11.2. Selection of installation place (Data from safety management regulations for high-pressure gas)

Gas detector for gas leakage detection alarm should be installed close to the leakage parts with a risk of gas leakage. However, for the places with easy dwelling of leaked gas although direct gas leakage is not expected, it should be installed at a spot such as No. 1 of the following places.

- Gas leakage detection alarm installed outside a building shall be installed at a spot for easy dwelling of gas by considering wind direction, wind velocity, specific gravity of gas, etc.
- When the specific gravity of the detection target gas is larger than that of air, the gas leakage detection alarm installed inside a building should be installed at a lower part in the building, while it should be installed near ventilation hole of the building or at an upper in the relevant building when the gas is lighter than air.
- Alarm of the gas leakage detection alarm should be installed at a place with the Gas detector installed and places for permanent residence of workers.

11.3. Notes upon installation

Positions with rainwater, etc. that can be an electrical obstacle should be avoided for installation, and installation at a place facilitating operation is recommended since periodic maintenance and repair is required. Since places with vibration or impact can affect output values, avoid those places with vibration or impact for installation, and install in such a way that the sensor unit is directed toward the direction of gravity.

- The present instrument has a pressure-resistant, explosion-proof structure, belonging to the GROUP II aimed at gas, vapor of general business places and chemical plants, and can be used for dangerous places of ZONE 1(ONE)-type and of ZONE 2(TWO)-type 2.
- Allowed temperature belong to lower than 85°C corresponding to T6
- In terms of ambient temperature, use in the range of -40 to 80 °C.
- Installation altitude: Less than 1,000M above sea level
- Relative humidity: 5% ~ 99%(Non-condensing)
- Installation place: Outdoors and indoors
- Explosion ignition group of target gas or vapor: Ex d IIC T6
- When explosion-proof cable gland is used at cable inlet or wiring construction for metal cable pipe is conducted upon wiring connection operation, electric conduit should be sealed to prevent moving of gas, etc. through electric cable conduit within 50mm or propagation of flames upon explosion.
- More than 5 threads should be made to be coupled upon connection of the present instrument and the electric cable pipe
- Conduct operation under the conditions satisfying other [Standards on selection, installation, and repair, etc. of electric machine, apparatus, wiring, etc. with explosion-proof structure for business places.
- For all materials used for cable lead-in such as CABLE GLAND and SEALING FITTING, etc. as well as materials used for finishing of unused lead-in unit, make sure to use the products having passed qualification
- Other places for easy dwelling of gas

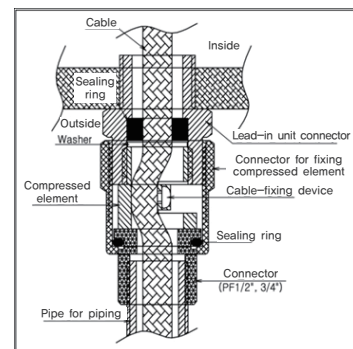

[Figure 21. Pressure-resistant packing type]

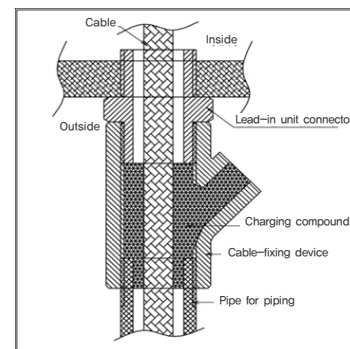

[Figure 22. Y Sealing Compound]

Version	Contents	Date
1.0	* Initial revision of manual	2011.06.27
1.1	* Change typo for CO measurement range (10% → 1.0%)	2011.07.13
1.2	* Revise Calibration Mode, Revise IR Sensor Data Mode	2011.07.25
1.3	* Add HART function	2012.04.03
2.0	* Add apparatus drawing and operation Flow, function	2012.08.21
3.0	* Revise current consumption and revise address	2013.01.28
4.0	* Add Maintenance Mode function	2013.03.28
5.0	* Add description on wire connection part for 485 communication * Modify Manual Version	2014.04.21
6.0	* Separate Factory Mode	2016.09.10.
7.0	* Change Cable Entry installation regulation for explosion-proof instrument 45cm → 50mm	2017.01.20
7.1	* Analog output Current – Over 110% LEL: Change 20mA ~ 21.4mA – 22mA * Initial operation state – Revise Self Test content * Revise GROUP OF GAS SEL Parameter Add SO2/VCM/FREON * Revise 7.2 CALIBRATION Menu change * Add content for FAULT 14	2017.07.04
7.2	* Correct typo for Fault Table and add content * Revision of apparatus-related drawing * Revision of block diagram for GIR-3000	2017.07.26
7.3	* Revise TABLE OF CONTENTS so as to start from item 3P * Revise measurement range 10,000ppm → 9,999ppm * Revise No.4 item DC 18 ~ 24V → DC 18 ~ 31V * Revise DC 18 ~ 24V → DC 18 ~ 31V * Revise value for Alarm1 Dead band Default 1.0 → 0.0 * Revise value for Alarm2 Dead band Default 1.0 → 0.0 * Revise HIGH SCALE ADJ. 1~10000 → 1~9999 * For filling of combustible and toxic substances → For charging	2017.08.18
7.4	* Arrange document form * Add wire connection diagram of driving method for 4~20mA 3wire sink	2017.09.06
7.5	* Correct typo * Change temperature specification * Add warning paragraph	2017.11.29